

Voltage Reference Compensates Reference Junction

This application note discusses how to use a precision voltage reference with a junction temperature pin (MAX873) to bias up the reference junction of various thermocouple types.

A voltage-reference IC with TEMP output (see the figure below) offers just the capabilities needed to compensate the reference junction of common thermocouples.

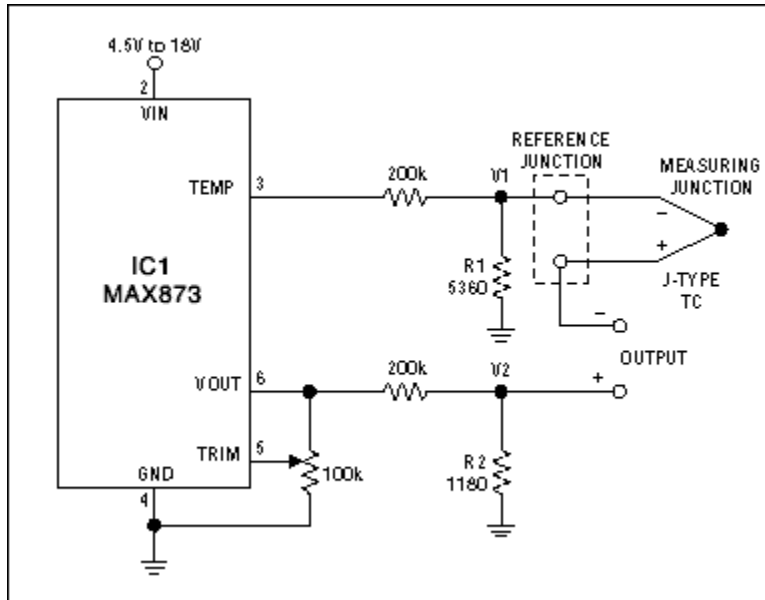

Using voltages generated at TEMP and VOUT by the voltage-reference IC, this circuit compensates the reference junction of a thermocouple.

A thermocouple is the junction of two dissimilar metals. It produces a small voltage (the Seebeck coefficient) that varies predictably with temperature:

Thermocouple Type (ANSI Designation)	Seebeck Coefficient
J (iron-constantan)	52.3 μ V/ $^{\circ}$ C
T (copper-constantan)	42.8 μ V/ $^{\circ}$ C
K (chromel-alumel)	40.8 μ V/ $^{\circ}$ C
S (platinum-{10% rhodium in platinum})	6.4 μ V/ $^{\circ}$ C

In practical setups, the voltmeter connections form a second thermocouple (the reference junction), and the measured voltage represents the *difference* in temperature between this reference and the thermocouple itself (the measuring junction). Thus, you must either maintain the reference junction at a known temperature, such as that of an ice bath, or apply a compensating voltage that makes the reference appear to be at 0 $^{\circ}$ C regardless of its actual temperature. An ice-bath stabilization produces the desired 0V output at 0 $^{\circ}$ C, but that approach is impractical for most applications.

IC1's reference output (VOUT) equals 2.5V, and its TEMP output is proportional to temperature, measuring 608mV at 25 $^{\circ}$ C with a temperature coefficient (TCV_{TEMP}) of 2mV/ $^{\circ}$ C. You should adjust R1 so

that V1 equals the thermocouple's Seebeck coefficient and R2 so that V2 equals the V1 output at 0°C. (For J-type thermocouples, R1 = 5360Ω and R2 = 1180Ω.)

For proper operation, the IC should be in thermal contact with the reference junction and all resistors should have temperature coefficients of ±5ppm/°C or better. To calibrate the system, adjust the potentiometer so that (V1 - V2) equals the thermocouple output voltage at the known ambient temperature.

D329, November 2000

MORE INFORMATION

MAX873: [QuickView](#)

-- [Full \(PDF\) Data Sheet \(312k\)](#)

-- [Free Sample](#)